

KBPC15005W thru KBPC1510W

15.0 A Single-Phase Silicon Bridge Rectifier Rectifier Reverse Voltage 50 to 1000V



Features

- This series is UL listed under the Recognized Component Index
- The plastic material used carries Underwriters Laboratory flammability recognition 94V-0
- Universal 4-way terminals, snap-on, wrap-around, solder or P.C. Board mounting
- Surge overload ratings to 300 amperes
- Electrically isolated metal case for maximum heat dissipation
- Case to terminal isolation voltage 2500V

Mechanical Data

Case: Metal case
 Terminals: Plated copper leads .04" (1.02 mm) diameter
 Weight: 1.007 ounce, 28.5 grams (approx)
 Mounting Position: Bolt down with silicone thermal compound between bridge and mounting surface for maximum heat transfer efficiency
 Mounting Torque: 20 in-lb max.

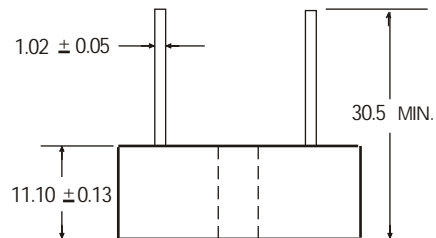
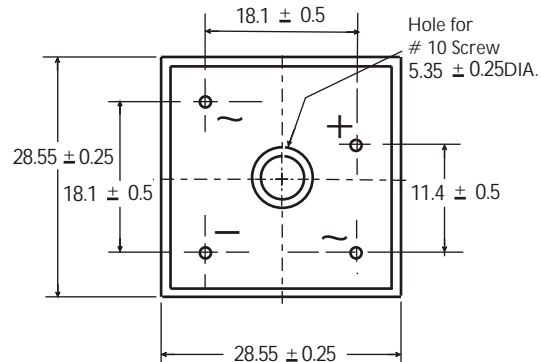

Dimensions in millimeters (1mm=0.0394")

Maximum Ratings & Thermal Characteristics

Rating at 25°C ambient temperature unless otherwise specified, Resistive or Inductive load, 60 Hz.
 For Capacitive load derate current by 20%.

Parameter	Symbol	KBPC	KBPC	KBPC	KBPC	KBPC	KBPC	KBPC	unit
		15005W	1501W	1502W	1504W	1506W	1508W	1510W	
Maximum repetitive peak reverse voltage	VRRM	50	100	200	400	600	800	1000	V
Maximum RMS bridge input voltage	VRMS	35	70	140	280	420	560	700	V
Maximum DC blocking voltage	VDC	50	100	200	400	600	800	1000	V
Maximum average forward rectified output current at TA=55°C	IF(AV)	15							A
Peak forward surge current single sine-wave superimposed on rated load (JEDEC Method)	IFSM	300							A
Rating for fusing (t<8.3ms)	I ² t	664							A ² sec
Typical thermal resistance per element(1)	ReJA	2.5							°C / W
Operating junction and storage temperature range	TJ, TSTG	-55 to + 150							°C

Electrical Characteristics

Rating at 25°C ambient temperature unless otherwise specified. Resistive or Inductive load, 60Hz.
 For Capacitive load derate by 20 %.

Parameter	Symbol	KBPC	KBPC	KBPC	KBPC	KBPC	KBPC	KBPC	Unit
		15005W	1501W	1502W	1504W	1506W	1508W	1510W	
Maximum instantaneous forward voltage drop per leg at 7.5A	VF	1.0							V
Maximum DC reverse current at rated TA =25°C DC blocking voltage per element TA =125°C	IR	10 500							μA

Notes: (1)Thermal resistance from Junction to Ambient on P.C.board mounting.

Rating and Characteristic Curves ($T_A=25^{\circ}\text{C}$ Unless otherwise noted)
KBPC15005W thru KBPC1510W

Fig. 1 Derating Curve for Output Rectified Current

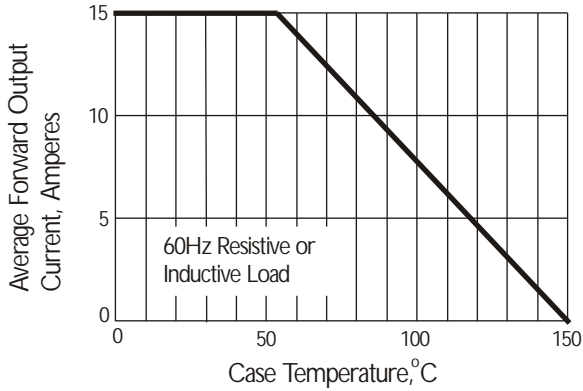

Fig. 2 Maximum Non-repetitive Peak Forward Surge Current

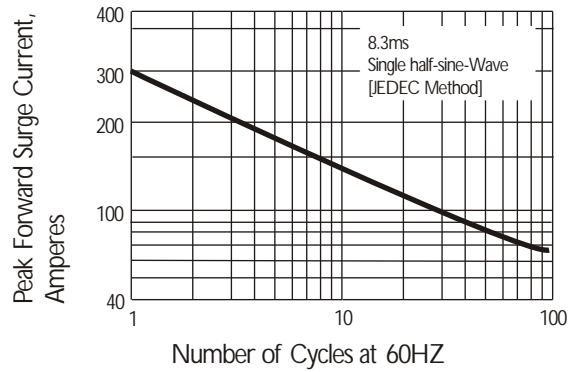

Fig. 3 Typical Instantaneous Forward Characteristics

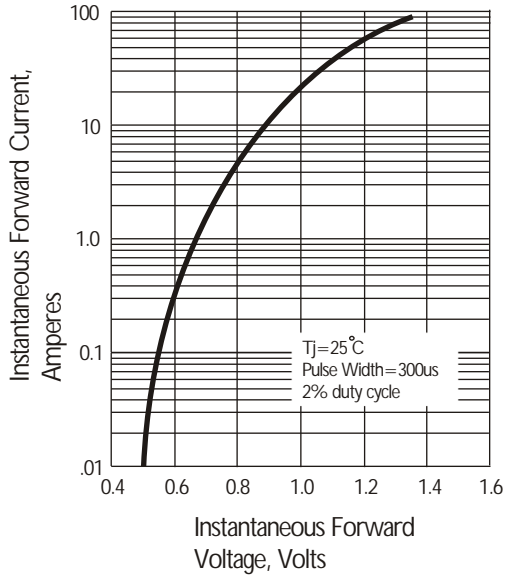

Fig. 4 Typical Reverse Characteristics at T_J=25°C

